



ENGINE GOVERNING SYSTEMS

PRODUCT INFORMATION BULLETIN

PIB2050

MAY 2000
MPC

175 SERIES ELECTRIC ACTUATOR

INTRODUCTION

The 175 SERIES electric actuator is designed to mount directly on a Bosch "P" size fuel injection pump, with a right hand, rack, in place of the mechanical governor. When the 175 actuator is installed on the fuel pump, an optimum performance, long life fuel control system results. An external fuel shut off lever is provided to manually override the actuator's control. Also provided is an adjustable internal maximum fuel limit.

The 175 Series Electric Actuator can control fuel pumps of up to 8 cylinders. The actuator was designed with two isolated chambers. The upper chamber is wet with oil and contains the connection to the fuel rack and an optional manual shut off mechanism. The sealed lower chamber contains the electromagnetic components.

This design eliminates the possibility of magnetic particles or other oil contaminants interfering with the operation of the electric actuator. Unreliable devices such as bellows and sliding seals are not used so that no maintenance is required. The designed life of the actuator is typically longer than that of the engine.

CHART A

	12V	24V	w/ Shutoff	w/o Shutoff	w/ Mating Conn	w/o Mating Conn
ACD175-12	*			*		*
ACD175-24		*		*		*
ACD175A-12	*		*			*
ACD175A-24		*	*			*
ACD175SA-12	*		*		*	
ACD175SA-24		*	*		*	
ACE175-12	*			*	*	
ACE175-24		*		*	*	
ACE175A-12	*		*		*	
ACE175A-24		*	*		*	

The 175 SERIES actuator can also be supplied with a position sensor that allows the actuator to be used in a fuel management system. Contact GAC for assistance.

SPECIFICATIONS

PERFORMANCE

Force(see Figure 1)	6.2 lb. (27.5 N)
Operating Stroke	0.80 in. (21 mm)
Response Time (10 - 90%, 2 - 19 mm)	35 msec.

ELECTRICAL POWER INPUT

Operating Voltage	12 or 24V DC
Nominal Operating Current	12V DC version4.0 A 24V DC version2.0 A
Maximum Current	12V DC version5.8 A 24V DC version3.1 A

ENVIRONMENTAL

Operating Temperature	-40 to +95°C (-40 to +200°F)
Relative Humidity	up to 100%
Vibration	20g, 20 - 500 Hz
Shock	20g @ 11 msec.

PHYSICAL

Dimensions	See Figure 2
Weight	4.75 lb. (2.2 kg.)
Mounting	Requires camshaft bearing retainer kit
	P3000 pumpKT275 P7000 pumpKT276
Mating Connector	EC1300
Mating Cable Harness	CH1215
Available Models	See Chart A

INSTALLATION

Preparing the fuel injection pump

If the fuel injection pump is equipped with a mechanical governor, it must be removed. GAC recommends that this modification be performed by a qualified fuel injection service facility. The following procedure lists the general steps required to remove the mechanical governor.

NOTE: Be prepared to collect the oil that will be released from the mechanical governor.

1. Remove the rear housing from the mechanical governor and disconnect the governor linkage from the fuel rack. Remove the flyweight assembly. A special tool is required.
2. Remove the intermediate governor housing. This leaves only the rack and camshaft protruding from the pump.
3. Install the camshaft bearing retainer plate to provide support to the bearing formerly held by the governor housing. This plate must have countersunk holes for the mounting screws.

Installing the actuator

All hardware needed to attach the actuator to the pump is located in kit KT289 supplied with the actuator.

1. The mounting surface of the pump must be clean and ready to accept the electric actuator.
2. Place the spring seat (1) over the fuel rack and slide it down to the body of the fuel pump. Slide the fuel rack return spring (2) over the fuel rack and against the spring. Attach the rack connection link assembly (4,5,6,29) to the fuel rack with 2 M5 X 10 retaining screws (3) that include patches of locking adhesive. Tighten the screws to 3 - 4 NM.
3. Remove both actuator covers (25,28) and swing the armature out of the actuator so that the lever (7) is out of the way. Place two M6 X 16 screws (22) and two spring washers (24) in the two lower mounting holes inside the actuator. Remove the adhesive protector from the gasket (23) and place it over the screws and adhere it to the mating surface of the actuator. Carefully slip the actuator over the fuel rack assembly until the two lower screws just start to meet the fuel pump mounting holes. With a ball end Allen screw wrench, tighten the two lower mounting screws (22) each a few turns. Once these two screws are fully threaded (do not tighten at this time) into the housing, thread two more M6 X 16 screws (22) and spring washers (24) into the two top mounting screws of the actuator. Tighten the four mounting screws to 5 - 6 NM.

4. Verify that the fuel rack is as far out of the pump as possible. Replace the lower actuator cover (28) and tighten the screws (27) to 4 - 6 NM.

Carefully loosen the screw (14) and nut (18) holding the bearing (17) onto the lever so that the bearing can slide in the lever's slot. While pulling back on the lever, slide the bearing forward until it just contacts the fuel rack connector, then push the bearing slightly forward, about 1 mm. Tighten the bearing mounting screw (14) to 4 - 6 NM.

5. Inspect the assembly to make sure all screws are tight and the fuel rack moves smoothly without any binding. Push in the fuel rack manually to full fuel and move the fuel shut off lever to minimum fuel to confirm that the shutoff fuel lever contacts the metal plate (29) on the fuel rack connector assembly and forces the fuel rack to minimum position.

6. The lever has a maximum fuel adjustment set screw (8). This screw is used to restrict the fuel rack from 1 to 14.5 mm

Setting high fuel levels may cause the maximum fuel adjusting screw to hit the top cover, which can change the minimum fuel position.

This could lead to a dangerous condition.

When setting fuel levels above 17 mm, insure that the adjusting screw does not contact the top cover at minimum fuel.

With the fuel pump operating on the engine, the maximum fuel setting can be set to provide specific horsepower. Once this setting is made tighten the lock nut (9) on the stop screw to S - 6 NM.

7. Move the manual shut off lever to the stop position and insure that the fuel is completely shutoff and the engine stops.

8. With the engine shut down, install the upper chamber cover (25) with the four screws (19,27) and lock washers. Note that when installed, the cover must not hit the internal lever or its stop screw. Tighten the screws to 2 - 3 NM. Check for any oil leaks. Lock wire the screws for tamper resistance.

CAUTION

The engine should be equipped with an independent shut down device to prevent overspeed which can cause equipment damage or personal injury.

WIRING

The 175 actuator is pre-wired for 12 or 24V DC operation. Use the included cable harness or make up a cable harness to connect the actuator to the speed control unit. DO NOT use 175 actuator on a 32V system. Contact the factory for assistance.

Coil Resistance

12V DC	24V DC
1.7 ± 0.2 OHMS	7.2 ± 0.5 OHMS

Figure 2 Actuator Outline

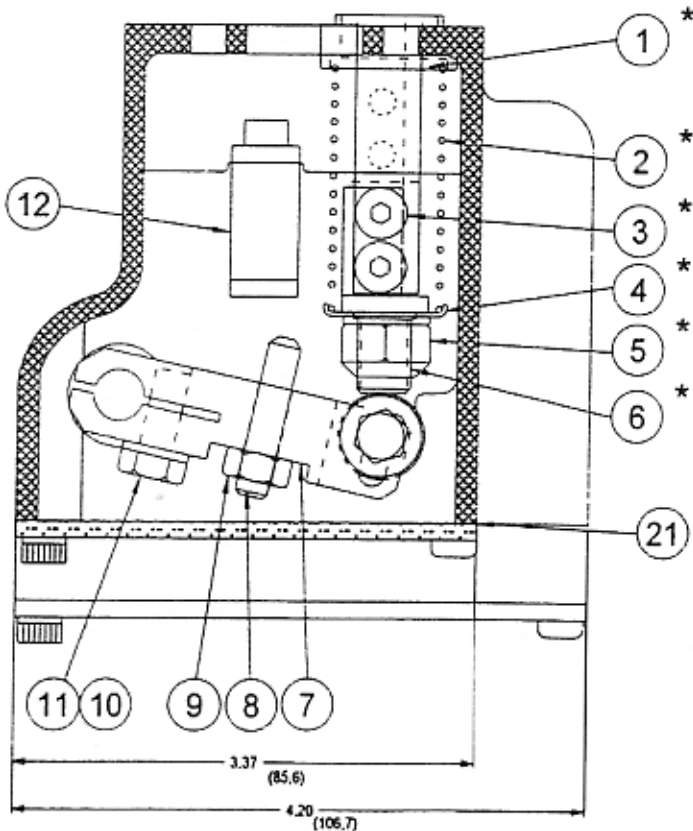

Parts marked * are supplied in kit KT289

Figure 1 ACE175 Fuel Rack Force vs. Stroke

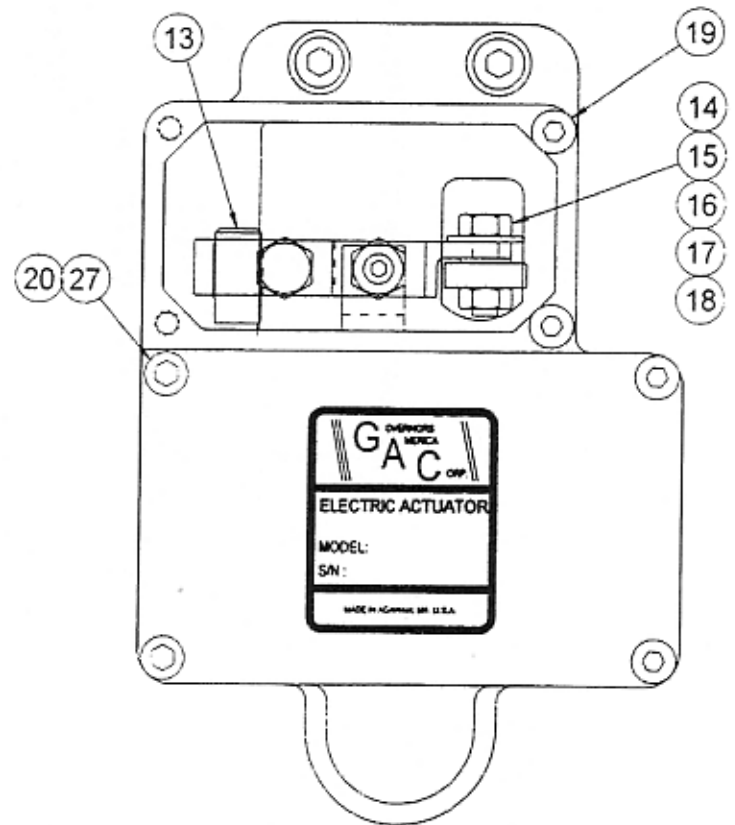
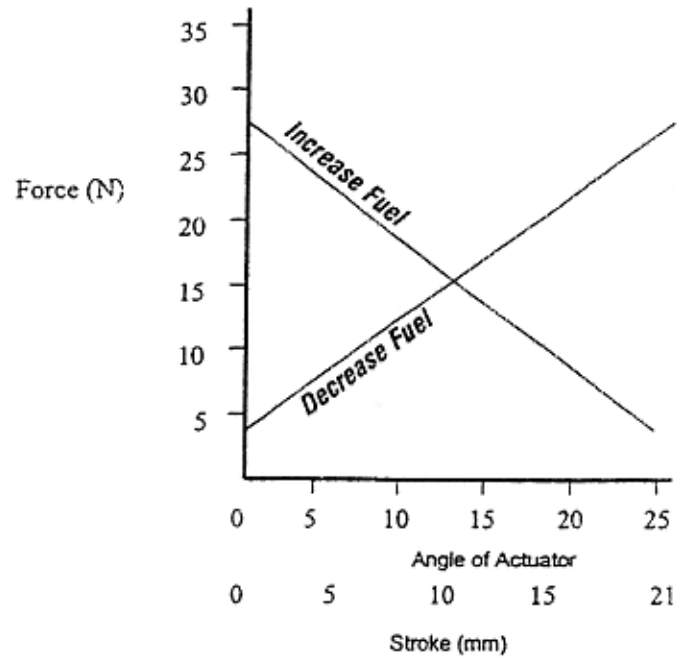

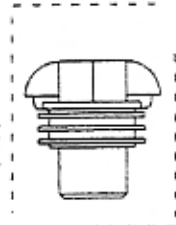
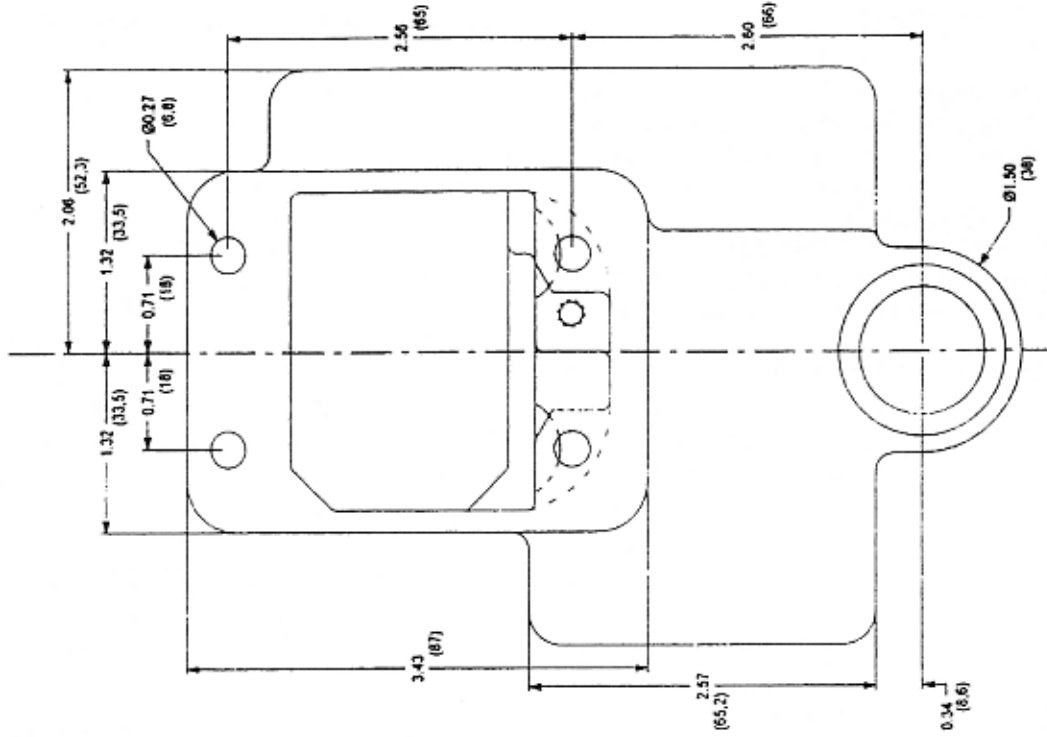
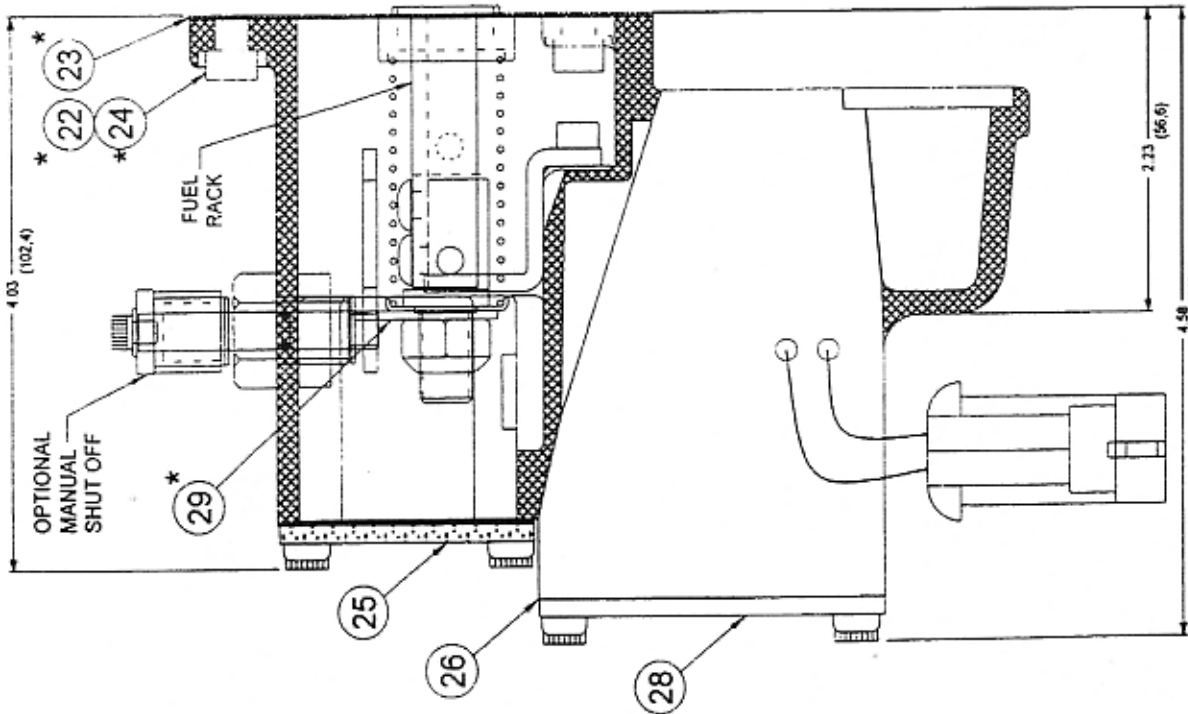

(31) (32) (33) PACKARD CONNECTOR 15300002
 WITH TERMINALS 12048159
 (33) (34) (35) MATING CONNECTOR 15300027
 WITH TERMINALS 12077411
 (SEE CHART A)

ELECTRONIC - HYDRAULIC - SYSTEMS

HUEGLI TECH AG 4900 LANGENTHAL SWITZERLAND
 TEL. + 41 62 916 50 30 FAX. + 41 62 916 50 35
 E - Mail : sales@huegli-tech.com www.huegli-tech.com