

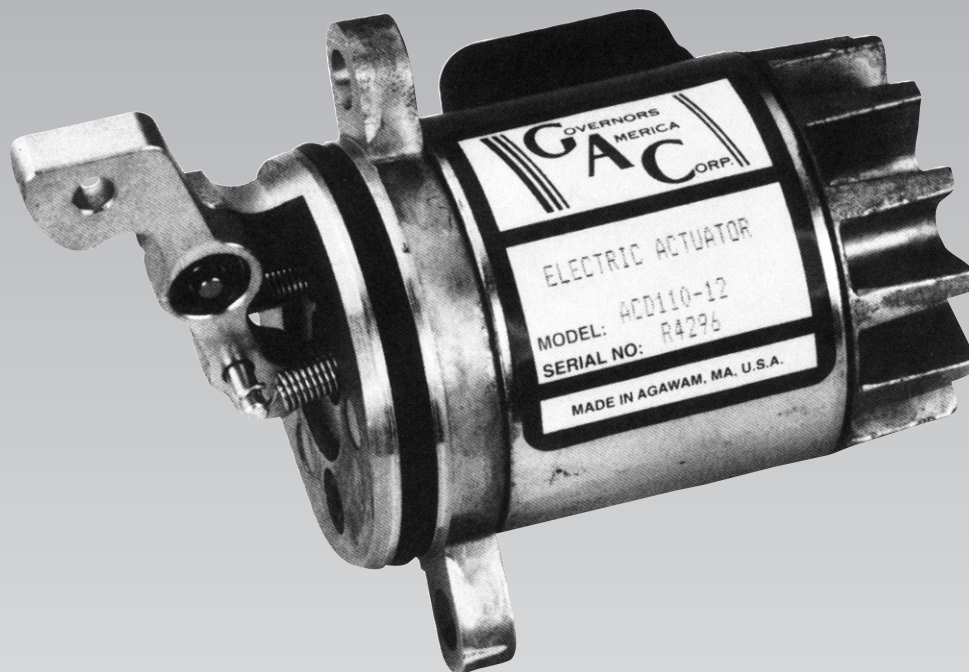

**ENGINE
GOVERNING
SYSTEMS**

100 SERIES



**INTEGRAL ACTUATOR
for DEUTZ 1011 TYPE ENGINES**

MEMBER

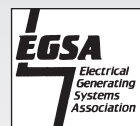

GOVERNORS AMERICA CORP. • 720 Silver Street • Agawam, MA 01001-2907, USA

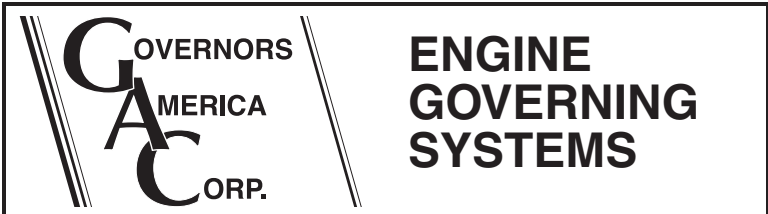

PRODUCT
TECHNICAL
INFORMATION

PTI 2060
October 2000
PIP South Hadley

110 SERIES

INTEGRAL ACTUATOR for DEUTZ 1011 TYPE ENGINES

INTRODUCTION

The 110 Series Integral Actuator is designed to mount directly to DEUTZ 1011 series 2, 3 and 4 cylinder engines in place of the electric stop solenoid. It exhibits high quality construction and is designed for high temperature operation. GAC's unique linear electromechanical technology provides proportional actuator movement, based on actuator coil current.

IMPORTANT When applying the 110 Series actuator to DEUTZ 1011, 4 cyl. engines, the engine must be equipped with DEUTZ'S extra start fuel spring #4174748.

This unique, optimum fuel control, actuating device will outperform externally mounted types of electric actuators. An integral high performance speed control system results when the 110 Series electric actuator is installed on the engine and electrically connected to complementing governor system components. No external linkages or brackets are required and no extra DEUTZ parts are needed. In addition, when the governor system is de-energized, the 110 Series electric actuator performs as a fuel shut off solenoid.

DEUTZ AG has approved the use of this actuator design for their 1011 Series engines. The 110 Series Electric Actuator is simple to install and is ideal for variable and constant speed engine governing applications (e.g.: Compressors, Generator Sets, Pumps, etc.).

The 110 Series actuator is an electromagnetic device which moves the fuel system control rack. It can be integrated into a closed loop speed control system.

SYSTEM DESCRIPTION

A basic engine speed control system is described as follows: The magnetic speed sensor generates an electrical signal that is proportional to engine speed. This signal is sent to the electronic speed control unit, which compares it to a preset engine speed setting. If the engine speed and the preset engine speed setting are not equal, the speed control unit changes the actuator current which alters the actuator's magnetic force. The actuator's output lever position is proportional to the magnetic force generated and is counterbalanced by two actuator return springs. The motion of the actuator lever against the fuel rack of the engine causes a change in fuel delivery until the engine speed equals the speed control unit preset speed setting.

Installing the 110 Series actuator does not defeat the engine's mechanical governor operation. During the installation process, the mechanical governor is set to a higher speed than the electric governor operating speed. In this configuration the mechanical governor acts as a speed limiter.

Shutdown of the DEUTZ engine is achieved by switching off the power supply to the speed control unit. The return springs on the actuator counteract the internal fuel rack spring in the engine and force the rack to zero fuel. The standard engine fuel shut off lever also remains functional and is not affected by the actuator installation.

Since the design incorporates precision parts of superior quality and is sealed from the environment, outstanding reliability results. No maintenance is required.

SPECIFICATIONS

POWER INPUT

Operating Voltage (Dedicated Coil)	12 or 24 VDC available
Typical Operating Current	4.0 Amps at 12 VDC
.....	2.0 Amps at 24 VDC
Maximum Current (Continuous)	7.0 Amps at 12 VDC
.....	3.5 Amps at 24 VDC

ENVIRONMENTAL

Operating Temperature Range	-40° to 212°F (- 40° to 100°C)
Relative Humidity	up to 100%
All Surface Finishes	Fungus Proof and Corrosion Resistant

PHYSICAL

Dimensions	See Diagram 1
Weight	1.5 lbs (.68 Kg)
Mounting	Directly on Deutz 1011 type 2, 3 and 4 cyl. engines

RELIABILITY

Testing	All Units 100% Tested
---------------	-----------------------

MATING HARDWARE

Wiring Harness - (2 Wire with Automotive Connector is not included w/Actuator)	CH1110
Mating Half Connector - (Connector is included w/ACE110 Series)	EC1120

PREPARING THE ENGINE

Move and lock the engine's throttle lever 10% to 15% above the desired governed speed.

WARNING: Remove the battery negative connection before proceeding

Be sure the actuator voltage rating matches the battery voltage (see label part number or voltage stamp on end cap.)

Before removing the engine's stop solenoid and replacing it with the 110 Series electric actuator, it is important that the surrounding area be clean. Remove any dirt using compressed air or a suitable cleaning solvent. Prevent any contaminants from entering the engine. If a solvent is used, place a suitable container underneath the stop solenoid to collect the waste solvent and dirt. Dispose of waste by an environmentally accepted method.

Follow the engine manufacturer's procedures and instructions for the removal of engine shrouds or protective covers. Disconnect the engine stop solenoid from the wiring harness. Continue with the procedures for removal of the standard engine stop solenoid. Carefully remove the stop solenoid from the engine block (hint: pull and hold the engine stop lever in the shutdown position, this will ease removal).

INSTALLING THE ACTUATOR

CAUTION: Improper engagement of the actuator to the engine's fuel rack can cause an engine overspeed condition. Only qualified technicians, trained on the 1011 engine should install the actuator.

1. Move the engine's mechanical governor shut down lever to the minimum fuel position (the rack will be pushed further into the engine block).
2. Orient the GAC 110 Series actuator so that the lever is at the 4 o'clock position looking from the back of the actuator.
3. Insert the actuator into the engine block bore leading with the lever at the 4 o'clock position. The lever will fit into a cavity inside the block in front of the fuel rack. Adding a little grease to the actuator's "O" ring will make the installation easier.
4. Guide the mounting flange diameter of the actuator into the bore ensuring that the "O" ring is properly aligned.
5. Push the actuator into the block until the mounting flange ears are flat against the engine surface. Release the engine shut-down lever.
6. Mount the actuator loosely by reusing the engine stop solenoid fasteners. Do not torque at this time.
7. Rotate the actuator in the engine fully counter-clockwise against the mounting fasteners. Torque the fasteners to the values recommended by DEUTZ. Replace all guards and shields in the actuator area.

8. The supplied mating half electrical connector (P/N EC1120) may be used to make up a wiring harness which will provide an electrical connection to the selected GAC speed control unit. See Diagram 1 on the back page.

WIRING

The 110 Series is designed to have a dedicated 12 or 24 volt coil. These actuators are respectively identified as shown in Chart A below. Ensure that the actuator voltage matches the battery supply voltage.

An actuator cable harness is used to link the 110 Series actuator to the selected GAC speed control unit. There are no polarity connections from the speed control unit to the actuator which need to be observed. The cable harness mating half connector, EC1120 provides a vibration resistant and environmentally sealed electrical connection. See the specific speed control unit literature for additional wiring information.

CHART A.

Actuator Series	12V	24V	w/ Mating Connector	w/o Mating Connector
ACD110-12	•			•
ACD110-24				•
ACE110-12	•		•	
ACE110-24		•	•	

TROUBLESHOOTING

If the electric governor system fails to operate and the actuator is suspected to be the problem, make the following tests.

Measure Coil Resistance (Room Temp.)

1.6 ohms 12 VDC
7.2 ohms 24 VDC

Measure Coil Isolation

>1M ohm to case

Remove actuator. Hold the actuator with lever side down. Manually move the actuator's shaft through its range by depressing the actuator's lever. No binding or sticking should occur. Energize the actuator to full fuel (follow steps in speed control unit publication). The actuator should operate smoothly throughout its entire stroke without any interruptions in motion.

If the actuator passes these tests, the problem is likely elsewhere in the governor or fuel system. Refer to the speed control unit troubleshooting publication.

DIAGRAM 1.

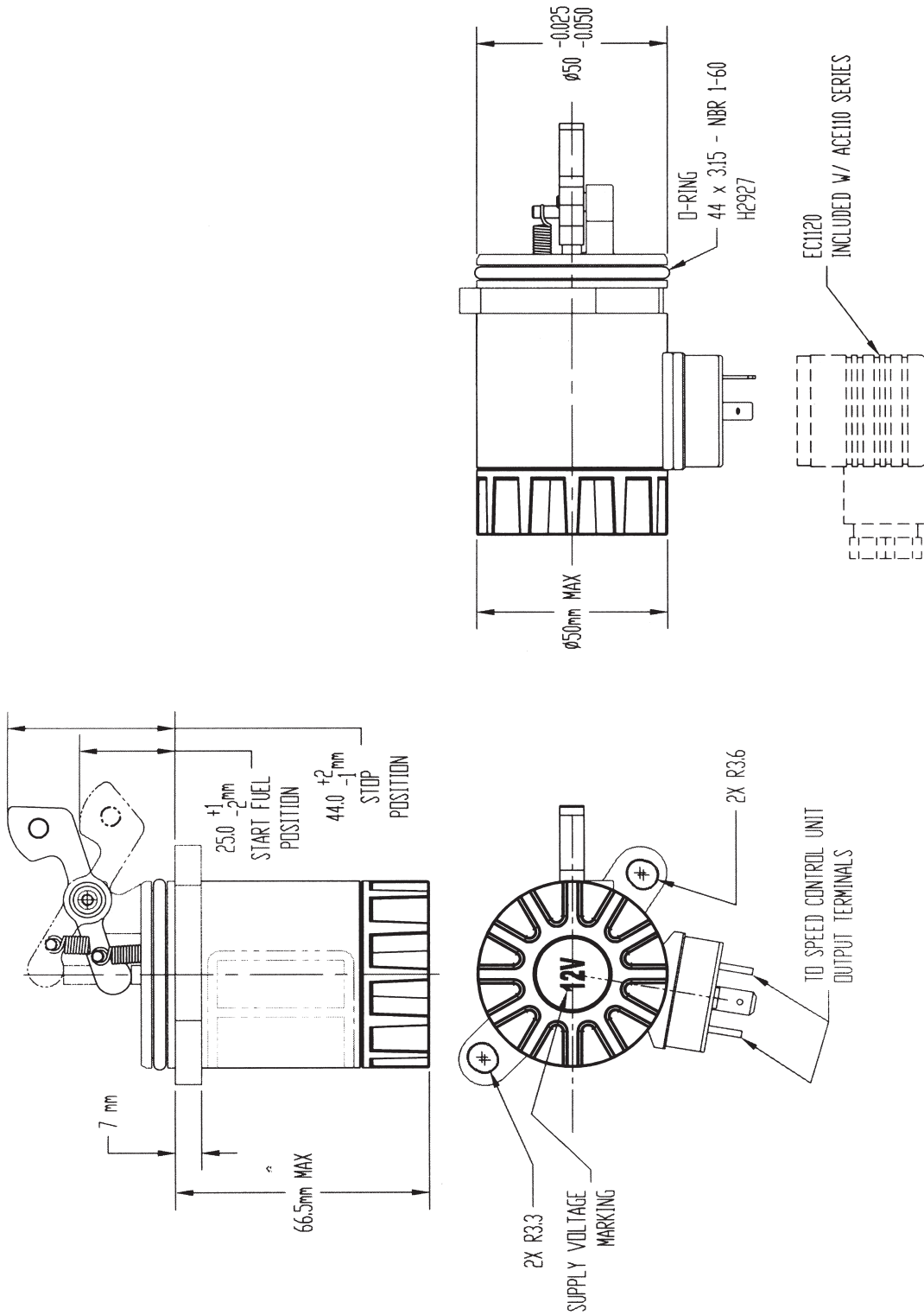

ELECTRONIC - HYDRAULIC - SYSTEMS

HUEGLI TECH AG 4900 LANGENTHAL SWITZERLAND

TEL. + 41 62 916 50 30

FAX. + 41 62 916 50 35

E - Mail : sales@huegli-tech.com

www.huegli-tech.com